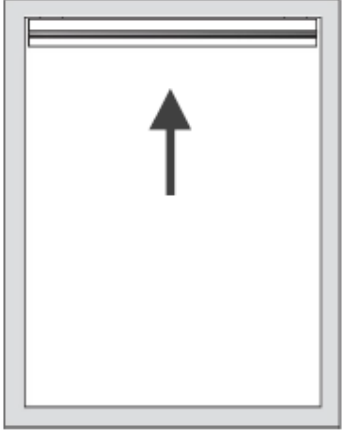
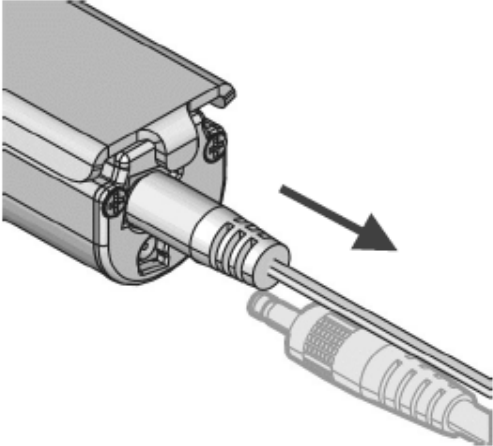

Demontageanleitung Akku-Funk-Antrieb EASE Typ M25S für Plissee und Jalousie

De-installation Instruction Accu Motor EASE Type M25S for Pleated Blind and Venitian Blind

- Entfernen der **Batterie** (Akku-Pack **EXTERN**) / *Removing the battery (External battery pack)*

Step 1		<p>Operate blind to the fabric stack position.</p> <p>Sonnenschutzanlage in die obere Endlage fahren.</p>
Step 2		<p>Disconnect power cable from external battery pack.</p> <p>Steckerverbindung vom externen Akkupack ziehen.</p>

Step 3

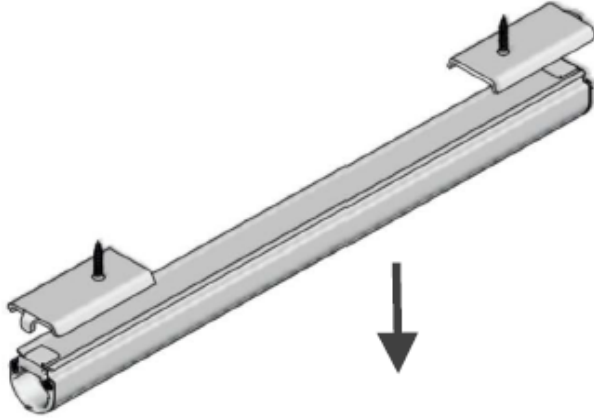

Remove external battery pack from mounting brackets.

Externes Akkupack von den Befestigungshaltern lösen.

Demontageanleitung Akku-Funk-Antrieb EASE Typ M25S für Plissee und Jalousie

De-installation Instruction Accu Motor Removal EASE Type M25S for Pleated Blind and Venitian Blind

- Entfernen der **Batterie** (Akku-Pack **INTERN**) / *Removing the battery (Internal battery pack)*

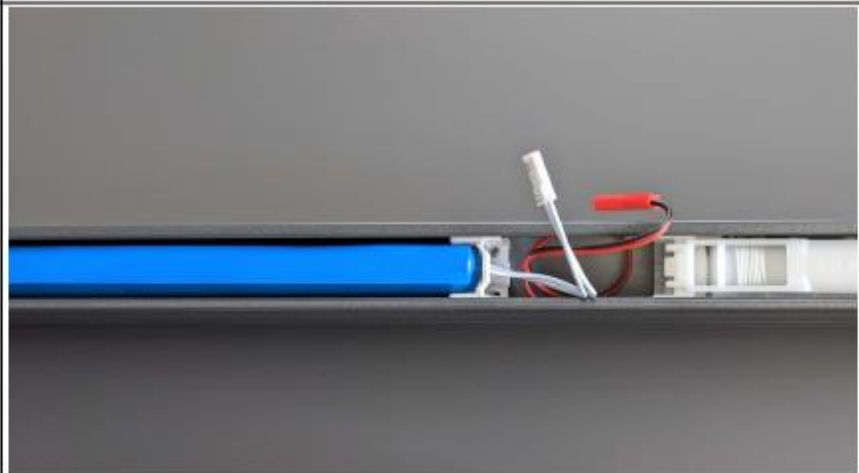
Step 1	 A photograph showing the disassembly of the blind's headrail. A grey endcap and a grey cover strip are shown above the headrail. The headrail itself is partially open, revealing a blue motor tube and a metal bracket.	<p>Remove endcap HeadRail XL20 and CoverStrip XL.</p> <p>Endkappe seitlich entfernen, ggf. Träger und Keder entfernen.</p>
Step 2	 A close-up photograph of the internal battery pack area. A blue motor tube is visible on the left. A white plastic connector is being pulled away from a red and black battery cable, which is plugged into a white terminal block on the right.	<p>Disconnect battery cable from internal battery pack.</p> <p>Kabelverbindung am internen Akkupack trennen.</p>

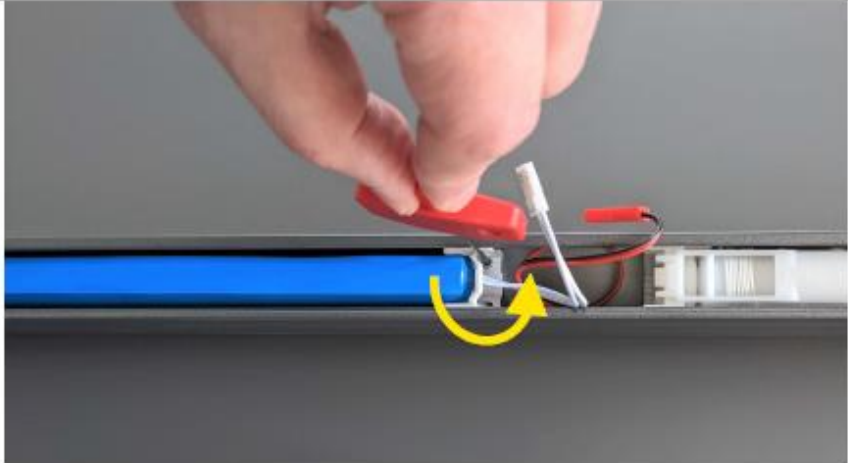
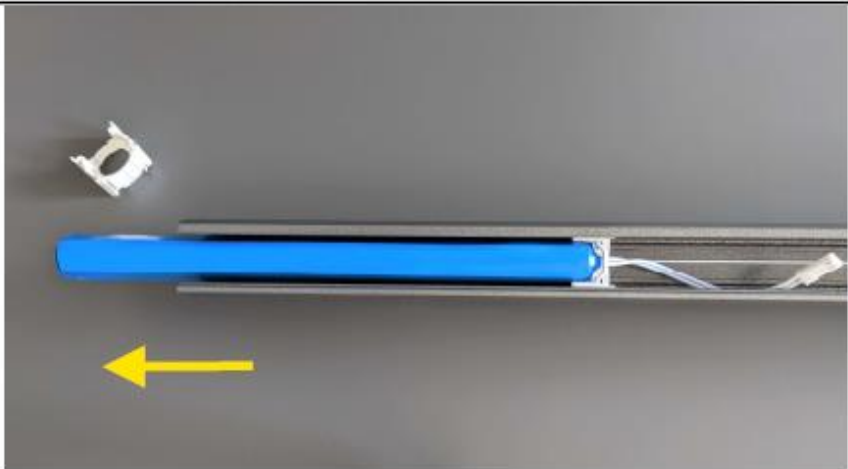

Step 3		<p>Untighten GrubScrew M3x8 to each Internal Battery Support.</p> <p>Träger lösen.</p>
Step 4		<p>Slide internal battery pack out of HeadRail XL20.</p> <p>Internes Akkupack aus der Oberschiene schieben.</p>



Demontageanleitung Akku-Funk-Antrieb EASE Typ M25S für Plissee und Jalousie

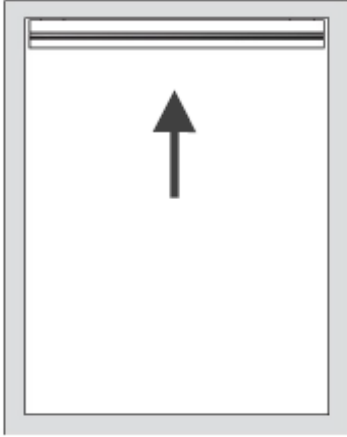
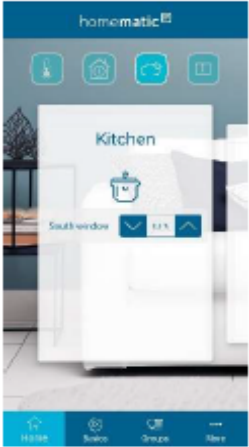

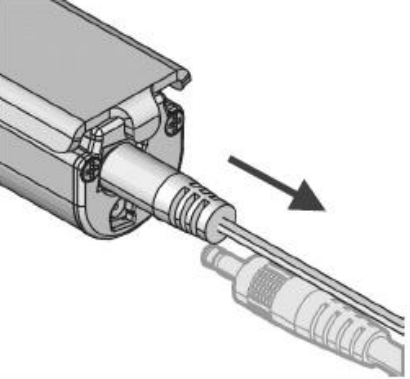
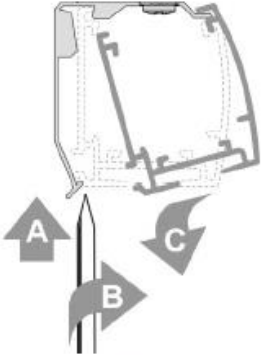
De-installation Instruction Accu Motor Removal EASE Type M25S for Pleated Blind and Venitian Blind

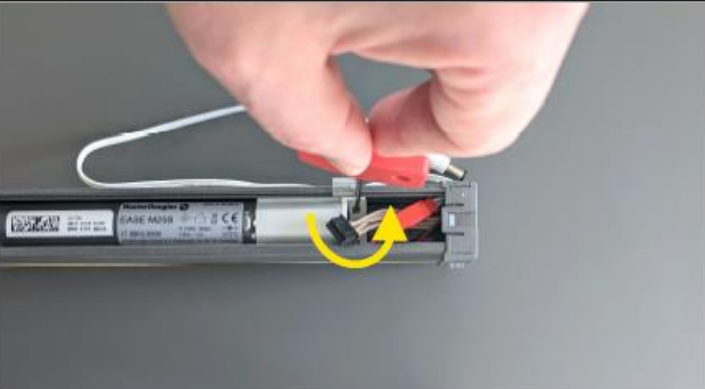

- Entfernen des **Motors** (Akku-Pack **EXTERN**) / *Removing the motor (External battery pack)*

Step 1		<p>Operate blind to the fabric stack position.</p> <p>Sonnenschutzanlage in die obere Endlage fahren.</p>
Step 2		<p>Open Homematic IP app (More → Device overview) and delete selected blind from the app. This will remove motor id connected to the Access Point and remote control.</p> <p>Die Homematic IP App öffnen > unten rechts auf Mehr ... > in der Geräteübersicht die Sonnenschutzanlage löschen. Verbindung zum Access Point wird gelöscht.</p>

Step 3		<p>Disconnect power cable from external battery pack.</p> <p>Steckerverbindung vom externen Akkupack ziehen.</p>
Step 4		<p>Remove HeadRail XL20 from installation clips.</p> <p>Sonnenschutzanlage aus den Befestigungshaltern entfernen.</p>
Step 5		<p>Remove endcap HeadRail XL20 and CoverStrip XL.</p> <p>Endkappe seitlich entfernen, ggf. Träger und Keder entfernen.</p>

Step 6		<p>Disconnect PCB cable from motor.</p> <p>Kabelverbindungen am Motor trennen.</p>
Step 7		<p>Untighten GrubScrew M3x8 to each Motor Support.</p> <p>Träger lösen.</p>
Step 8		<p>Remove PCB Cover.</p> <p>Abdeckung entfernen.</p>

Step 9		<p>Remove screw 2.2x8 from PCB Holder.</p> <p>Platine lösen.</p>
Step 10		<p>Remove PCB Holder and PCBA from HeadRail XL20.</p> <p>Endkappe inkl. Platine herausziehen.</p>
Step 11		<p>Remove PCBA from PCB Holder.</p> <p>Platine aus Endkappe lösen ggf. weitere Verbindungen trennen.</p>



Step 12		<p>Slide motor out of HeadRail XL20.</p> <p>Motor seitlich aus Oberschiene schieben, ggf. Kraft anwenden.</p>
Step 13		<p>Remove Motor Support from motor. Squeeze together shaft adaptor click fingers, to disengage from motor.</p> <p>Wellenverbindung zum Motor entfernen.</p>
Step 14		<p>Remove Motor Support from opposite end of motor.</p> <p>Seitliche Motorträger vom Motor entfernen.</p>

Demontageanleitung Akku-Funk-Antrieb EASE Typ M25S für Plissee und Jalousie

De-installation Instruction Accu Motor Removal EASE Type M25S for Pleated Blind and Venitian Blind

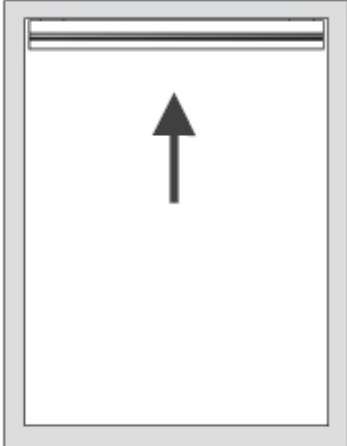
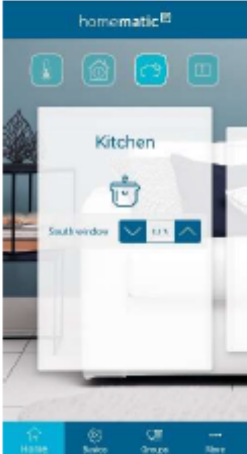

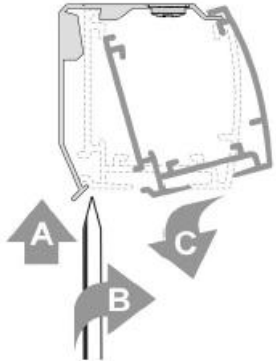
- Entfernen des **Motors** (Akku-Pack **INTERN**) / *Removing the motor (Internal battery pack)*

Step 1		<p>Operate blind to the fabric stack position.</p> <p>Sonnenschutzanlage in die obere Endlage fahren.</p>
Step 2		<p>Open Homematic ^{IP} app (More → Device overview) and delete selected blind from the app. This will remove motor id connected to the Access Point and remote control.</p> <p>Die Homematic IP App öffnen > unten rechts auf Mehr ... > in der Geräteübersicht die Sonnenschutzanlage löschen. Verbindung zum Access Point wird gelöscht.</p>

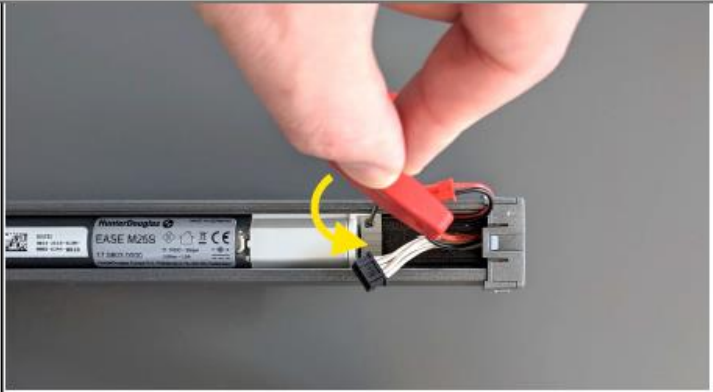
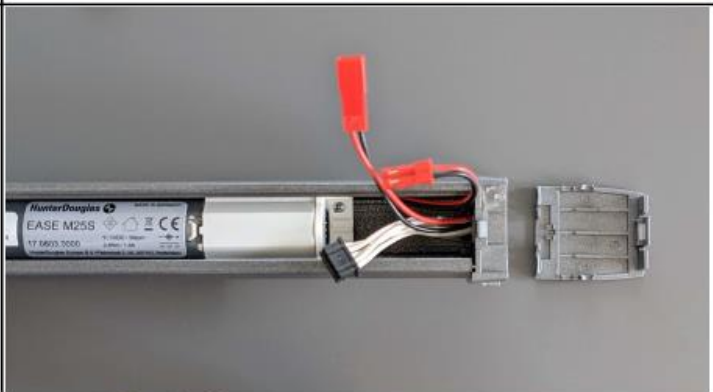
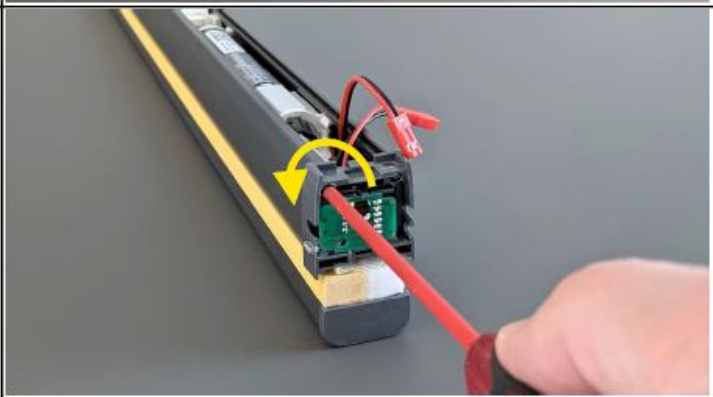
Step 3		<p>Remove HeadRail XL20 from installation clips.</p> <p>Sonnenschutzanlage aus den Befestigungshaltern entfernen.</p>
Step 4		<p>Remove endcap HeadRail XL20 and CoverStrip XL.</p> <p>Endkappe seitlich entfernen, ggf. Träger und Keder entfernen.</p>
Step 5		<p>Disconnect battery cable and PCB cable from motor.</p> <p>Kabelverbindungen am Motor trennen.</p>

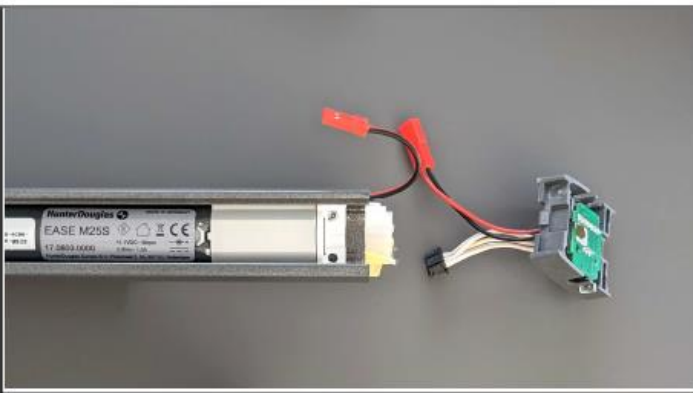
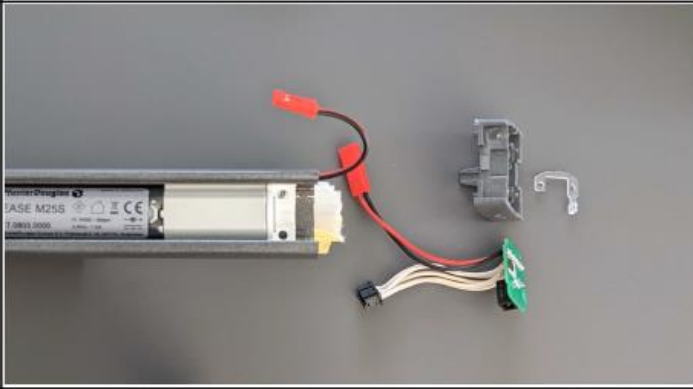
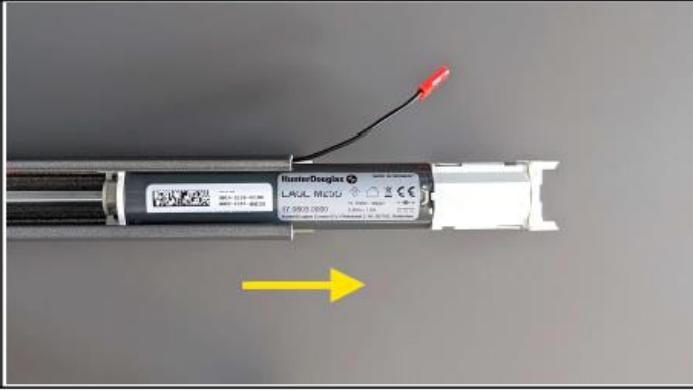
Step 6		<p>Untighten GrubScrew M3x8 to each Motor Support.</p> <p>Träger lösen.</p>
Step 7		<p>Remove PCB Cover.</p> <p>Abdeckung entfernen.</p>
Step 8		<p>Remove screw 2.2x8 from PCB Holder.</p> <p>Platine lösen.</p>

<p>Step 9</p>		<p>Remove PCB Holder and PCBA from HeadRail XL20.</p> <p>Endkappe inkl. Platine herausziehen.</p>
<p>Step 10</p>		<p>Remove PCBA from PCB Holder.</p> <p>Platine aus Endkappe lösen ggf. weitere Verbindungen trennen.</p>
<p>Step 11</p>		<p>Slide motor out of HeadRail XL20.</p> <p>Motor seitlich aus Oberschiene schieben, ggf. Kraft anwenden.</p>

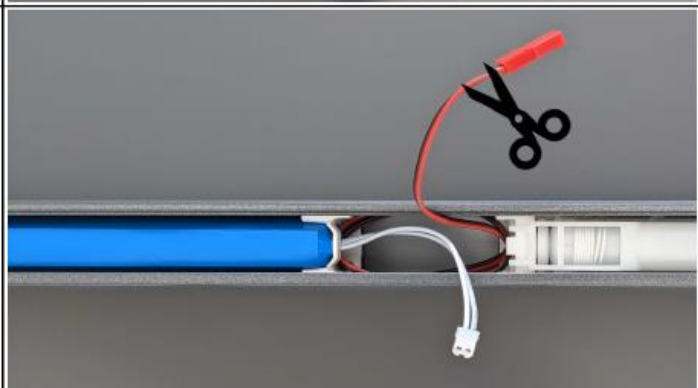
Step 12		<p>Remove Motor Support from motor. Squeeze together shaft adaptor click fingers, to disengage from motor.</p> <p>Wellenverbindung zum Motor entfernen.</p>
Step 13		<p>Remove Motor Support from opposite end of motor.</p> <p>Seitliche Motorträger vom Motor entfernen.</p>
Step 14		<p>Disconnect battery cable from internal battery pack. Cut away plug connector from battery cable.</p> <p>Kabelverbindungen entfernen, ggf. Stecker abschneiden.</p>

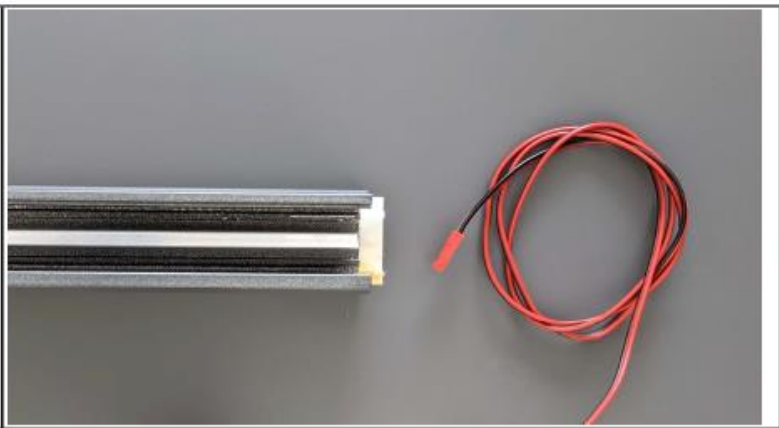
Step 15		<p>Pull battery cable out of HeadRail XL20.</p> <p>Kabel aus der Oberschiene herausziehen.</p>
---------	--	--

Entsorgung/ Rückgabe

Elektrobauteile können kostenlos bei kommunalen Sammelstellen abgegeben werden z.B. Wertstoffhof oder an den Vertreiber (Händler) zurückgebracht werden.



Disposal/ Return

Electrical components can be disposed of free of charge at community waste disposal centers or centers of electrical equipment or brought back to the distributor (dealer).